



280-1342M



HUB MOTORS™
a quality product line of Assembled Products Corporation

**24 Volt DC - 8" Red (Solid Rubber Tire)
With Electrically Released Brake**

Max Capacity: 400 Lbs. [181 kg]
Weight: 10.6 Lbs. [4.8 kg]
Sound Level: <74 db @ 6" [152 mm]

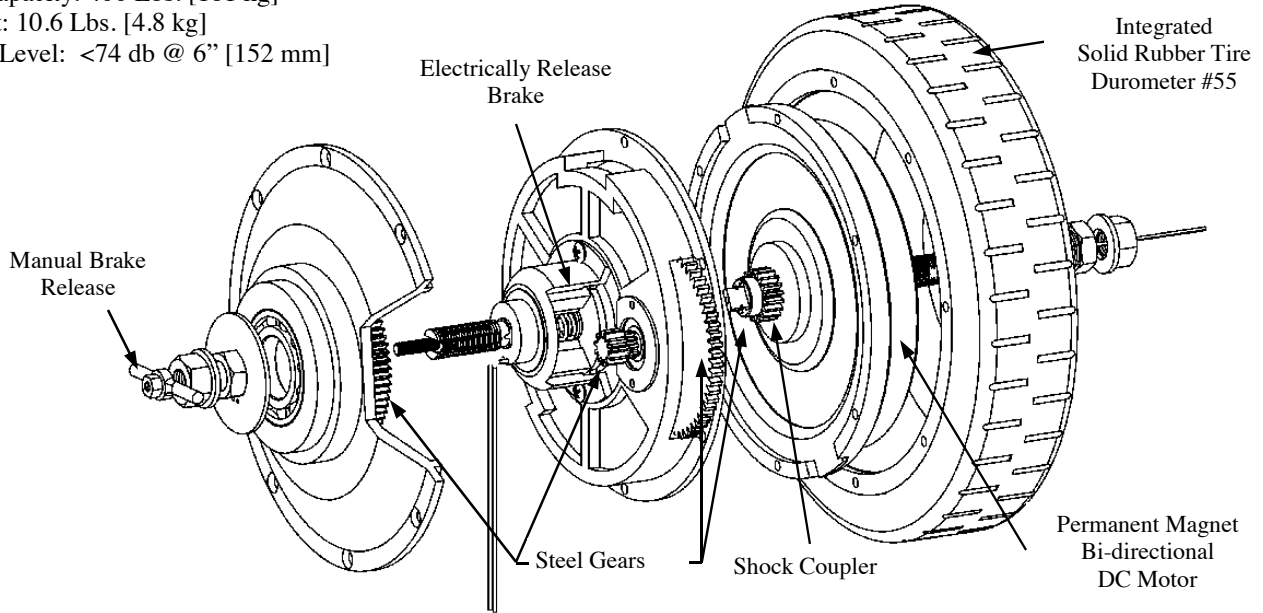

Performance Data @ 24VDC

			Power			Torque		Force @ Wheel		Speed			Efficiency
	Volts DC	Amps	Watts In	Watts Out	HP Out	Ft-Lbs	N.m	Lbs	N	RPM	MPH	KPH	
No Load	24.07	0.80	19.37	10.67	0.01	0.46	0.62	1.37	1.86	164.5	4.0	6.5	55.1%
Max Eff.	24.05	3.47	83.47	63.65	0.09	2.95	4.00	8.84	12.00	152.0	3.7	6.0	76.3%
Max Power Out (Continuous Duty)	23.93	10.87	260.12	173.90	0.23	9.90	13.44	29.71	40.32	123.6	3.0	4.9	66.9%
Stall / Lock Rotor	25.40	58.00	1473.20			45.00	61.07	135.00	183.20	<i>Results will vary.</i>			
Brake	18-28	.94-.80	19.20			16.66	22.61	49.98	67.82				

Dimensions

