



280-1600M



**HUB MOTORS™**

a quality product line of Assembled Products Corporation

## 12 Volt DC - 8" Blue (Solid Rubber Tire) With Electrically Released Friction Disc

PATENT  
PENDING

Max Capacity: 400 Lbs. [181 kg]  
Weight: 10.6 Lbs. [4.8 kg]  
Sound Level: <70 db @ 6" [152 mm]

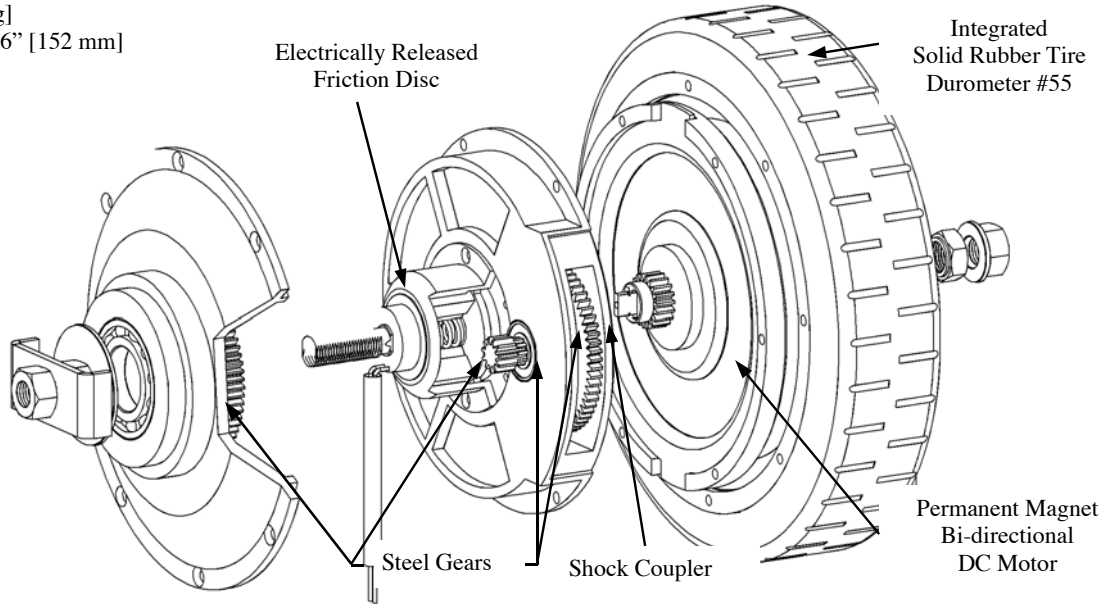

### Performance Data @ 12VDC

			Power			Torque		Force @ Wheel Dia.		Speed			Efficiency
	Volts DC	Amps	Watts In	Watts Out	HP Out	Ft-Lbs	N.m	Lbs	N	RPM	MPH	KPH	
<b>No Load</b>	12.10	0.61	7.42	2.02	0.003	0.17	0.23	0.51	0.69	84.2	2.1	3.3	27.2%
<b>Max Eff.</b>	12.07	3.36	40.61	26.49	0.04	2.60	3.53	7.80	10.59	71.7	1.8	2.8	65.2%
<b>Max Power Out (Continuous Duty)</b>	12.01	7.64	91.82	53.31	0.07	6.45	8.75	19.34	26.25	58.2	1.4	2.3	58.1%
<b>Lock Rotor</b>	12.77	33.00	421.41			26.67	36.19	80.01	108.57	<i>Results will vary.</i>			
<b>Friction Disc</b>	8-14	.82-.55	6.60			8.30	11.26	24.90	33.79				

### Dimensions

